

Differential Lock Valve Series MT..DV



1 General

1.1 Product description

The differential lock valve consists essentially of a bi-directional flow divider (dividing and combining) and a directional valve for optionally bypassing the flow divider. It is intended for use in either open- or closed-loop hydrostatic drives with parallel-connected hydraulic motors.

When the lock valve is switched OFF, the inlet flow can divide itself among the motors in any required manner.

When the lock valve is switched ON, however, the inlet flow is divided into two pressure compensated portions in accordance with the division ratio of the lock valve. The motors are thus driven at fixed speeds, regardless of their respective loads. This arrangement prevents any hydraulic wheel motor from spinning in conditions of poor traction.

A balancing orifice can optionally be arranged between the outlets A and B. This allows some redistribution of flow and prevents unwanted torque build-up between wheels in these circumstances, and when turning.

The differential lock valves can be supplied with either hydraulic, or electro-hydraulic, actuation.

1.2 Advantages

- robust and reliable
- these valves do not require maintenance. This lowers costs and reduces the risk of a system failure.
- precision operation without the use of costly electronics
- attractive price/performance ratio

2 Symbols

2.1 Hydraulic actuation

Balancing orifice can be fitted

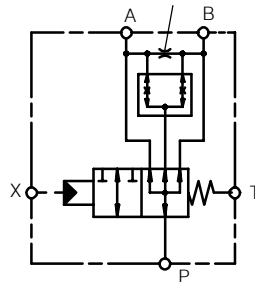

2.2 Electro-hydraulic actuation

Balancing orifice can be fitted

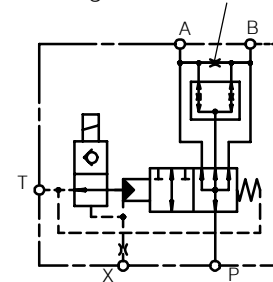

3 Technical data

3.1 Hydraulic characteristics

		Size 08	Size 16
Inlet flow $Q_{max}^{1)}$	l/min	100	200
Nominal flow rate $^{2)}$	l/min	25, 50, 75, 100	120, 160, 200
Operating pressure p_{max}	bar	420	
Pilot pressure $p_{p min.} - p_{p max.}$	bar	10 to 30	
Viscosity range	mm ² /s	10 to 380	
Fluids		Mineral oil to DIN 51524 (HL, HLP) For other fluids, contact Bucher	
Fluid temperature range	°C	-20 to +70	
Division ratio $^{3)}$		1:1	

3.2 Electrical characteristics

Voltage	V	12 or 24 DC
Power consumption	W	30
Duty cycle	ED %	100
Ambient temperature	°C	max. +80
Coil temperature	°C	max. +140
Enclosure protection DIN 40050		IP65 $^{4)}$
Electrical connection		Connecting plug to DIN 43650

- 1) State the application's effective nominal flow when ordering
- 2) Note the minimum flow per section 4.2
- 3) For other division ratios, contact Bucher
- 4) When the plug is fitted correctly

4 Performance graphs

4.1 Pressure drop (at 35 mm²/s)

Dividing function switched OFF

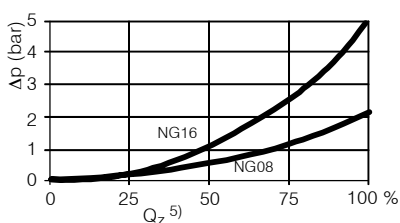

Dividing function switched OFF

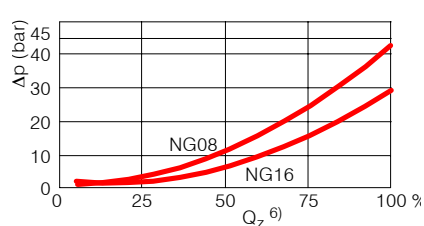

4.2 Division accuracy

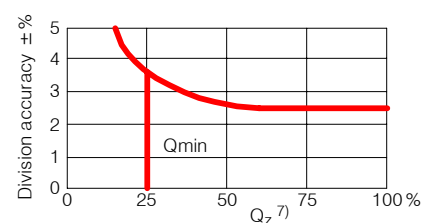

- 5) As a percentage of the maximum flow
- 6) As a percentage of the applicable nominal flow
- 7) Without a balancing orifice between A and B (hole plugged)

5 Dimensions

5.1 MT08DV

Hydraulic actuation MT08DV...-H-...

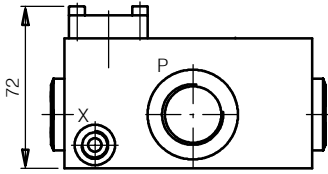

Port threads:

Port P	M27 x 2
Ports A and B	M22 x 1,5
Ports X and T	M12 x 1,5

Electro-hydraulic actuation MT08DV...-EH-...

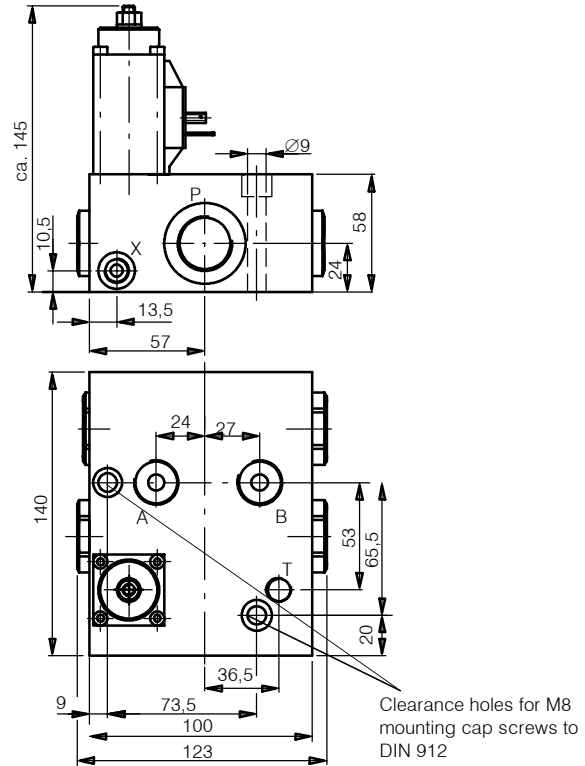

5.2 MT16DV

Hydraulic actuation MT16DV...-H-...

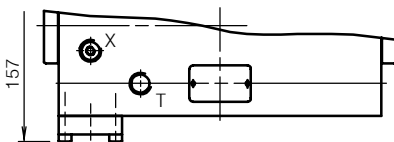

Port threads:

Port P	M 33 x 2, alternatively SAE (3000 PSI) R 1 1/4
Ports A and B	M 27 x 2, alternatively SAE (3000 PSI) R 1"
Ports X and T	M 12 x 1,5

For SAE flanges, see data sheet 414.08.116

Electro-hydraulic actuation MT16DV...-EH-...

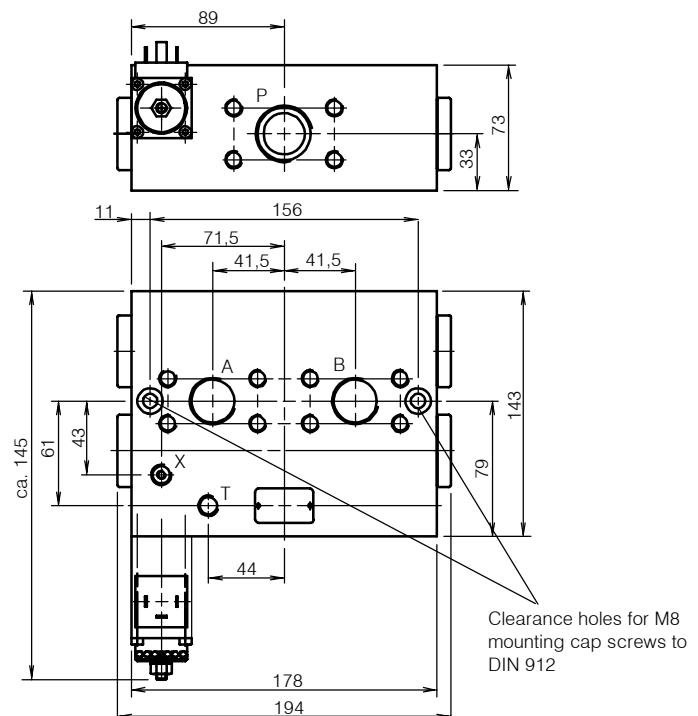

6 Ordering code

		M T 0 8 D V		1 0		0 2 5		- E H -		0 G 1 2		D ... ⁹⁾
Differential lock valve	=	MT..DV										
Nom. size	=	08 or 16										
Division	1 : 1	= 10										
	1:1,5 etc. 8)	= 15										
Nominal flow rate per. sect. 3.1	e. g. 25 l/min	= 025										
Type of actuation	hydraulic	= *H										
	electro-hydraulic	= EH										
Design no.												
Coil voltage	12V DC	= G12										
	24V DC	= G24										
	with actuation type *H	= ***										

8) With unequal division, the larger flow goes to port B

9) Size of balancing orifices must be plainly stated (see also sect. 2) e.g. 0.6 / 0.8 / 1.0 etc.
e.g. if balancing orifice D is to be 0.8 mm, then D = 0.8

7 Applications

7.1 2-wheel drive

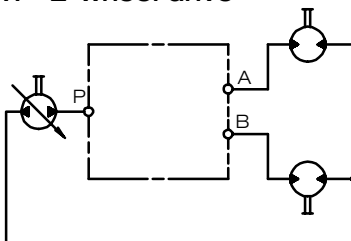

7.2 4-wheel drive

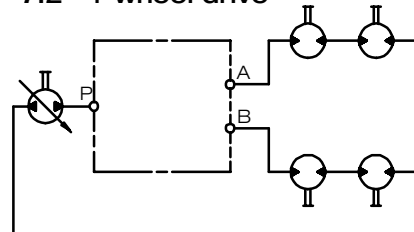

8 Installation

Horizontal mounting is recommended.
Do not bolt the valve body onto an uneven mounting surface.

BUCHER HYDRAULICS

Germany

Phone +49 7742 85 20
Fax +49 7742 71 16
info.de@bucherhydraulics.com

France

Phone +33 389 64 22 44
Fax +33 389 65 28 78
info.fr@bucherhydraulics.com

Netherlands

Phone +31 79 34 26 24 4
Fax +31 79 34 26 28 8
info.nl@bucherhydraulics.com

UK

Phone +44 24 76 35 35 61
Fax +44 24 76 35 35 72
info.uk@bucherhydraulics.com

USA

Phone +1 262 605 82 80
Fax +1 262 605 82 78
info.wi@bucherhydraulics.com

Switzerland

Phone +41 33 67 26 11 1
Fax +41 33 67 26 10 3
info.ch@bucherhydraulics.com

Italy

Phone +39 0522 92 84 11
Fax +39 0522 51 32 11
info.it@bucherhydraulics.com

Austria

Phone +43 6216 44 97
Fax +43 6216 44 97 4
info.at@bucherhydraulics.com

China

Phone +86 10 64 44 32 38
Fax +86 10 64 44 32 35
info.bj@bucherhydraulics.com

Product Center (Elevator)

Phone +41 41 757 03 33
Fax +41 41 755 16 49
info.nh@bucherhydraulics.com

We reserve the right of modification without prior notice.

www.bucherhydraulics.com