

Flow Control Valves Series MTKA, MTQA, MTCA



1 General

1.1 Product description

Series MTKA, MTQA and MTCA priority flow control valves provide a constant, pressure-compensated, flow of hydraulic fluid in one direction. They divide an inlet flow into a constant, priority, flow and a surplus flow.

The priority flow setting can be fixed or adjustable and the valves are used to regulate the speed of hydraulic actuators (cylinders, motors, etc.).

1.1.1 MTKA flow control valve

The MTKA priority flow control valve divides the inlet flow into a priority flow (fixed, or manually adjustable) and a surplus flow. The surplus flow can be pressurised and can therefore be supplied to an additional actuator. The pressure in the inlet line corresponds to that of the actuator with the highest load.

Additional applications:

The valve can also be used as a 2-way flow control valve by plugging the surplus flow port B.

1.1.2 MTQA flow control valve

The MTQA priority flow control valve divides the inlet flow into a priority flow (fixed, or manually adjustable) and a surplus flow.

The whole inlet flow is protected by an adjustable pressure relief valve. The surplus flow from port R should be returned directly to tank. The pressure in the inlet line corresponds to that of the actuator with the highest load.

1.1.3 MTCA flow control valve

The MTCA priority flow control valve divides the inlet flow into a priority flow (fixed, or manually adjustable) and a surplus flow. Both flows can be pressurised independently of each other and

both are protected by an adjustable pressure relief valve functioning in the inlet flow. The pressure in the inlet line corresponds to that of the actuator with the highest load.

If the priority flow stops (e.g. when cylinder reaches its end stop), then the oil is throttled down from load pressure and is combined with the surplus flow. If the surplus flow also stops, then the total inlet flow is relieved at the relief valve setting and exits through port T to tank.

1.2 Advantages

- robust, uncomplicated, reliable
- these valves do not require maintenance. This lowers costs and reduces the risk of a system failure.
- can be provided with customised mechanical or electrical actuation
- attractive price/performance ratio

2 Symbols

2.1 MTKA...

Priority flow (A) is fixed

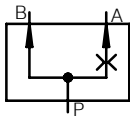

Priority flow (A) is adjustable

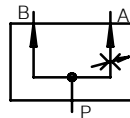

Bypass check valve from A to P

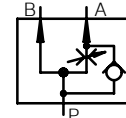

2.2 MTQA...

Priority flow (A) is fixed

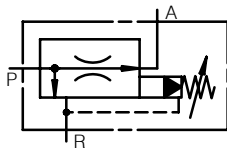

Priority flow (A) is adjustable

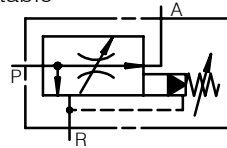

Bypass check valve from A to P

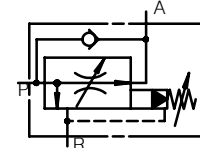

2.3 MTCA...

Priority flow (A) is fixed

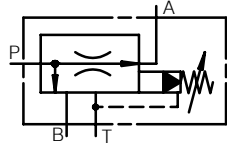

Priority flow (A) is adjustable

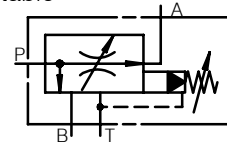

P = pump

A = priority flow

B = surplus flow

R = return line to tank

T = tank (no back pressure)

3 Technical data

		MTKA, MTQA	MTCA
Maximum operating pressure	bar	315	
Nominal flow rate Q (inlet flow)	l/min.	max. 70	80
Priority flow, fixed setting ¹⁾	l/min.	3, 6, 9, 12, 16	3, 6, 9, 12, 16, 25, 40
Priority flow, adjustable ¹⁾	l/min.	VA=0 to 12, VB=0 to 25, VC=0 to 50, VD=0 to 65	
Control accuracy	%	± 5	
Pressure differential Δp	bar	3,5 to 5	4 to 10
Fluid temperature range	°C	-20 to +80	
Viscosity range	mm ² /s	10 to 300	
Leakage, priority flow, at min. control setting ²⁾	cm ³ /min	50	

1) for other priority flows/flow ranges, contact Bucher

2) measured with surplus flow not under pressure

4 Performance graphs

The values refer to a viscosity of 33 mm²/s. Flow from P to A varies with the scale setting (adjustable models).

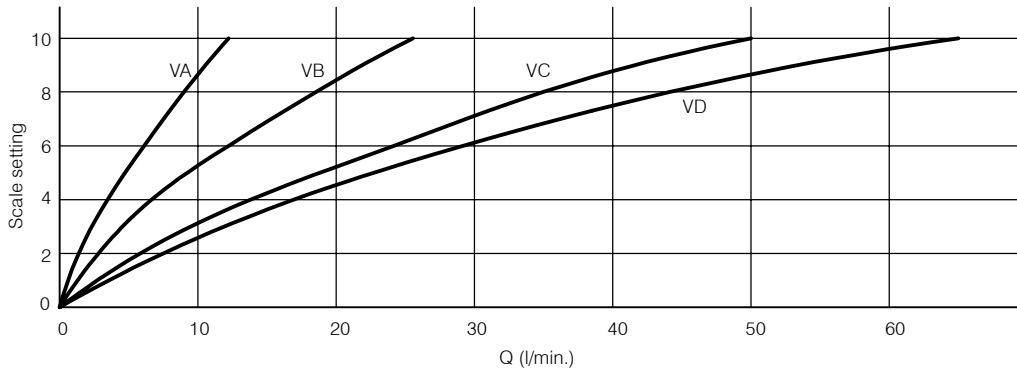

Adjustment ranges:

VA = 0-12 l/min

VB = 0-25 l/min

VC = 0-50 l/min

VD = 0-65 l/min

5 Dimensions

5.1 MTKA

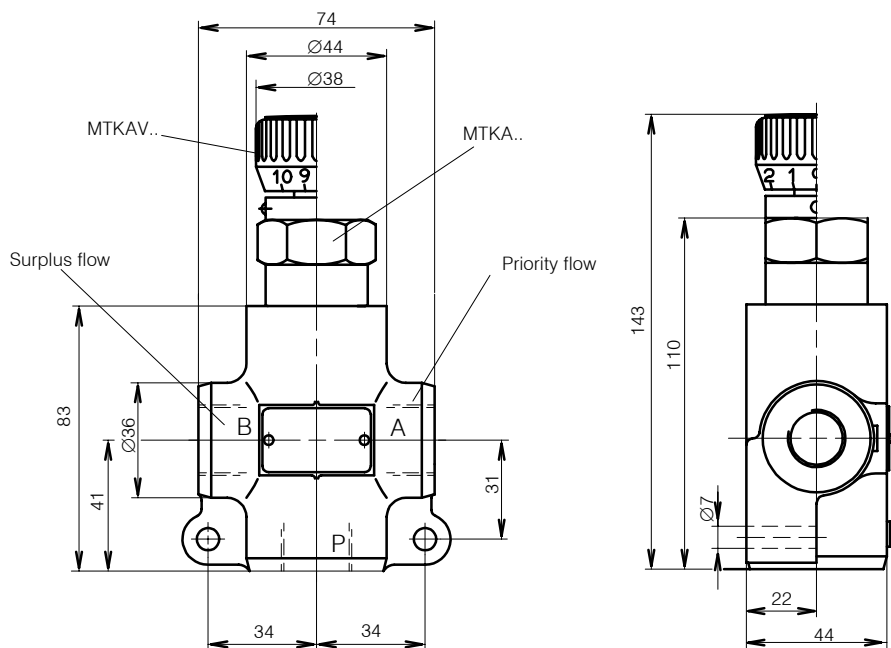

Size of ports P, A and B = M22 x 1,5

Weight 1,2 kg

5.2 MTQA

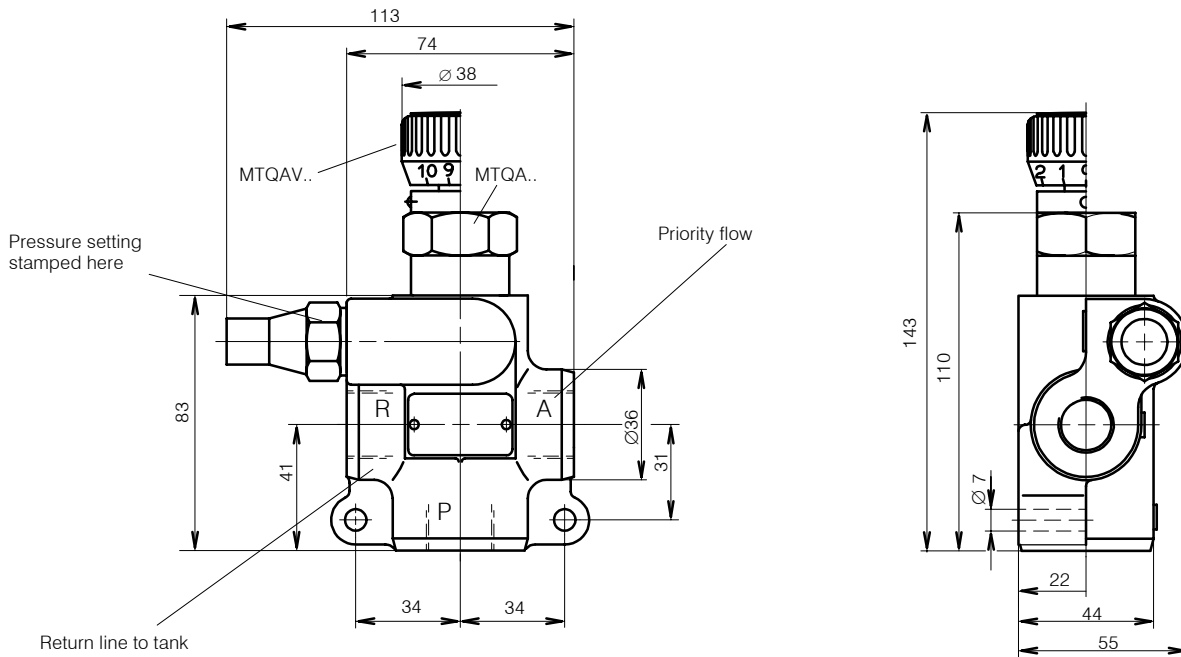

Size of ports P, A and R = M 22 x 1,5

Weight: 1,3 kg

5.3 MTCA

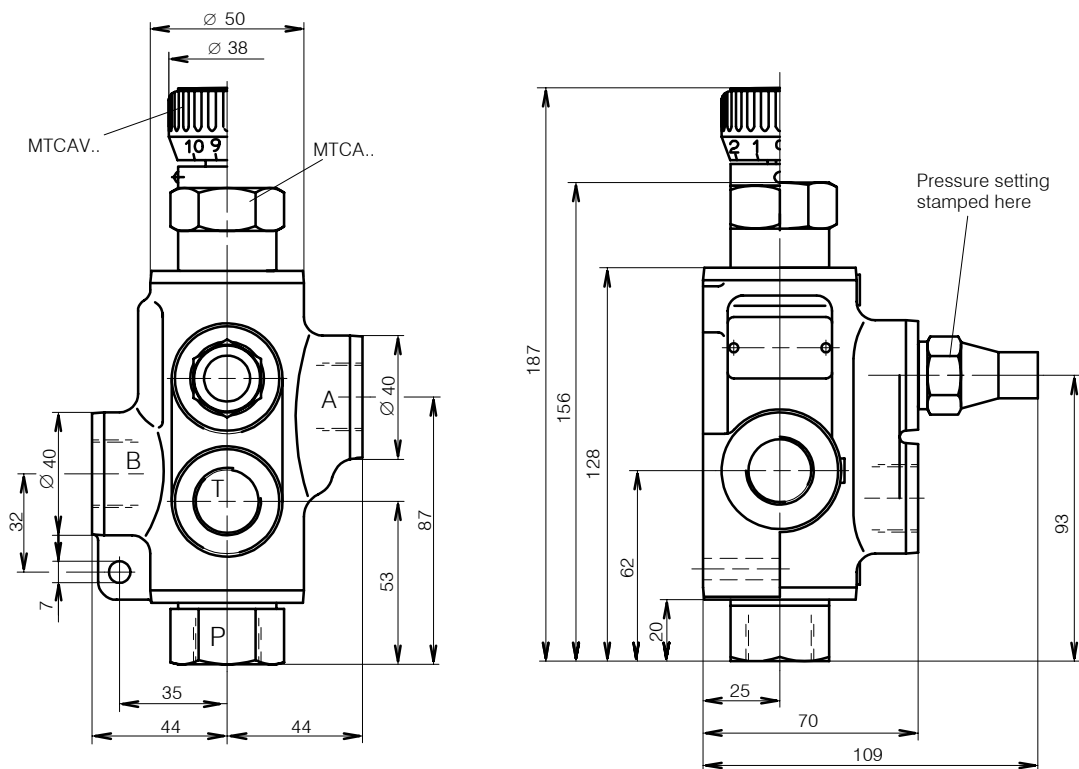

Size of ports P, A, B and T = M 22 x 1,5

Weight: 2,6 kg

6 Ordering code

6.1 MTKA.., MTQA..

		M	T	K	A	V	A	R	-		M	2	2	/	
Flow control valve	MTKA, MTQA														
Adjustable priority flow range	0 to 12 l/min = VA 0 to 25 l/min = VB 0 to 50 l/min = VC 0 to 65 l/min = VD														
Fixed priority flow rate	9 l/min = 09 12 l/min = 12 etc.														
Bypass check valve from A to P see 2.1															
Design no. (to be inserted by the factory)															
Ports A, B, P and R	M22 x 1,5 = M22														
Special features (to be inserted by the factory)															

Please specify the required pressure setting in the order text (MTQA only)

6.2 MTCA..

		M	T	C	A	V	A	-		M	2	2	/	
Flow control valve	MTCA													
Adjustable priority flow range	0 to 12 l/min = VA 0 to 25 l/min = VB 0 to 50 l/min = VC 0 to 65 l/min = VD													
Fixed priority flow rate	9 l/min = 09 12 l/min = 12 etc.													
Design no. (to be inserted by the factory)														
Ports A, B, P and T	M22 x 1,5 = M22													
Special features (to be inserted by the factory)														

Please specify the required pressure setting in the order text

For fitting an electric motorised drive to adjustable valves, see data sheet P000067, SAMO Actuator Unit

BUCHER HYDRAULICS

www.bucherhydraulics.com

Germany

Phone +49 7742 85 20
Fax +49 7742 71 16
info.de@bucherhydraulics.com

France

Phone +33 389 64 22 44
Fax +33 389 65 28 78
info.fr@bucherhydraulics.com

Netherlands

Phone +31 79 34 26 24 4
Fax +31 79 34 26 28 8
info.nl@bucherhydraulics.com

UK

Phone +44 24 76 35 35 61
Fax +44 24 76 35 35 72
info.uk@bucherhydraulics.com

USA

Phone +1 262 605 82 80
Fax +1 262 605 82 78
info.wi@bucherhydraulics.com

Switzerland

Phone +41 33 67 26 11 1
Fax +41 33 67 26 10 3
info.ch@bucherhydraulics.com

Italy

Phone +39 0522 92 84 11
Fax +39 0522 51 32 11
info.it@bucherhydraulics.com

Austria

Phone +43 6216 44 97
Fax +43 6216 44 97 4
info.at@bucherhydraulics.com

China

Phone +86 10 64 44 32 38
Fax +86 10 64 44 32 35
info.bj@bucherhydraulics.com

Product Center (Elevator)

Phone +41 41 757 03 33
Fax +41 41 755 16 49
info.nh@bucherhydraulics.com

We reserve the right of modification without prior notice.