

Internal Gear Flow Divider

Series QXT



1 General

1.1 Product description

Series QXT flow dividers are internal gear units that can divide a flow into as many as four portions. The division ratios are constant and are unaffected by the loads at the actuators. They can be used, for example, to provide synchronised movement of unequally loaded cylinders. Several hydraulic motors can be driven at the same speed, irrespective of their external loads.

Since they operate on the principle of the rotating internal gear set, these flow dividers work without any throttling losses, which is in strong contrast to spool-type flow dividers.

The QXT flow divider can also be used to produce pressure intensification i.e. the outlet pressure from the flow divider is higher than its inlet pressure. This

takes place at high efficiency, since the operating principle ensures that the only losses that can possibly occur are proportional to the pressure difference across the unit.

The unit is based on the well-known QX internal gear pump, which is distinguished by its very low noise levels and almost imperceptible pressure pulsations. The large number of closely spaced sizes ensures that the right size is always available for every application.

1.2 Advantages

- flow divider has a wide flow range, thanks to wide speed range of the internal gear sets
- very low noise levels
- negligible pressure pulsations
- 320 bar max. can be attained with single-stage flow dividers

- hydrodynamic bearing support ensures long service life
- optimised flow path cross-sections and special gear profile give low susceptibility to cavitation
- high efficiency, since operating principle ensures there are no throttling losses
- high efficiency, since internal leakage is determined only by the pressure difference across the divider, and not by system pressure
- a very wide range of division ratios is available
- The inlet flow can be divided into as many as four portions
- high division accuracy
- also suitable for special fluids such as HFC, environmentally friendly or low viscosity fluids

2 Technical data

Type	Outlet displacement cm ³ /rev	Cont./ Intern. pressure ¹⁾ bar	Speed max/min rpm	Maximum inlet flow Q ₀		
				2 outlet flows	3 outlet flows	4 outlet flows
				l/min	l/min	l/min
QXT 22	5	250/320	6300/1250	63	95	125
	6			80	120	160
	8			100	150	200
QXT 32	12	250/320	5000/1000	120	180	240
	16			160	240	320
QXT 42	25	250/320	4000/800	200	300	400
	32			250	380	500
QXT 52	50	250/320	3200/630	320	480	640
	63			400	600	800
QXT 62	100	250/320	2500/500	500	750	1000
	125			630	950	1260
QXT 82	200	250/320	2000/400	800	1200	1600
	250			1000	1500	2000

The technical data apply to flow dividers with outlet flows of equal sizes. Please contact Bucher if you require unequal outlet flows.

1) Intermittent for max. 20 sec/min but not than 10% of the duty cycle

For the highest division accuracy as well as the lowest cost, choose the smallest possible flow divider running near its maximum speed. The speed n in rev/min is calculated from:

$$n = \frac{Q_0 \times 10^3}{V_1 + V_2 + V_3 + \dots}$$

where Q_0 = inlet flow rate in l/min and V_1 = outlet displacement in cm^3/rev . The minimum permissible inlet flow rate is calculated from:

$$Q_{0 \text{ min.}} = \frac{n_{\text{min.}}}{n_{\text{max.}}} \times Q_{0 \text{ max.}}$$

In the case of the flow dividers with unequal outlet displacements, use the largest displacement for determining $n_{\text{max.}}$, the smallest for $n_{\text{min.}}$. Since rotary flow dividers are also pressure intensifiers, each outlet circuit must be provided with a pressure relief valve. Bucher Hydraulics series VT relief valves mount directly on the flow divider and

are therefore particularly suitable (please request the VT catalogue).

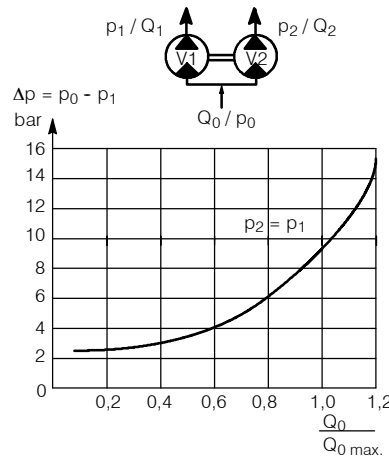

3 Performance curves

Tests carried out on a QXT flow divider, type 32-016/32-016, produced the results shown below. For the same speed, larger flow dividers have a better accuracy while smaller ones display

a bigger difference between the two outlet flows.

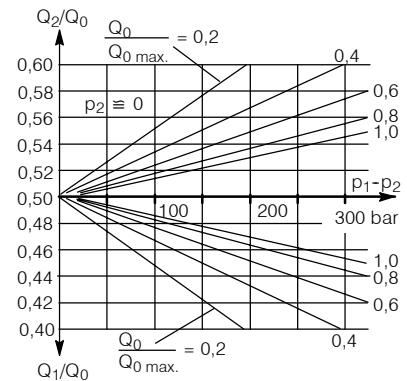

The division accuracy of the outlet flows Q_1 and Q_2 depends mainly on the pressure difference between the two outlet lines and the ratio $Q_0/Q_{0 \text{ max.}}$. The pressure drop across the flow divider is dependent on $Q_0/Q_{0 \text{ max.}}$. Using the curves, the accuracy of flow division and the pressure drop can be optimised.

4 Dimensions

Frame size	2	3	4	5	6	8
J2 (SAE)	G 1/4"	G 1 1/2"	2"	3"	3 1/2"	4"
J3 (SAE)	G 1"	G 1 1/4"	1 1/2"	2"	2 1/2"	3"
E (SAE)	G 1/2"	G 3/4"	1"	1 1/4"	1 1/2"	2"
A	118	132	170	212	267	330
B	100	106	146	181	229	280
C	9	11	14	18	22	26
N	63	82,55	101,6	127	152,4	200
O	8,5	8,5	10,5	12,5	16,5	20
V	6	6	7	7	7	9
G	M8x12	M8x12	M10x16	M10x20	M16x28	M20x30
K2	102	129	159,5	190	230,5	282,5
K3	37,5	44	52,5	60,5	74	130,5
L2	204	258	319	380	461	565
L3	313,5	393,5	480,5	572,5	685,5	851
L4	384	490	604	720	865	1062
Z	50	60	62,5	78	97,5	125
Q3	55	69,5	87	102	119	151
Q2	67	87	110,5	127	149	178,5
M3	168	301,5	261,5	315	374	469,5
M4	180	232	285	340	404	497
y	55	60	75	90	112	140
T	85	107	133	177	220	275

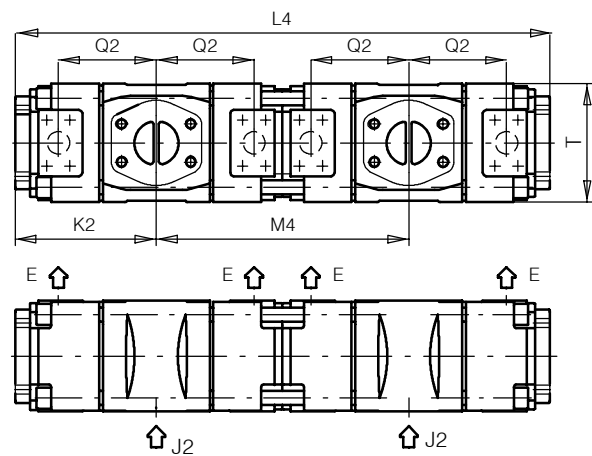
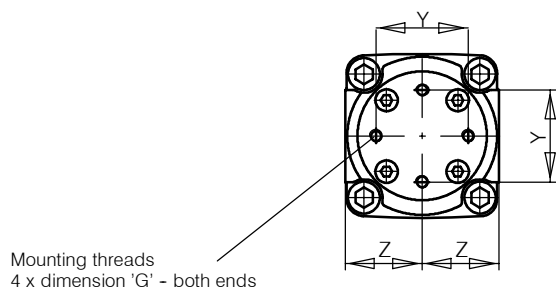
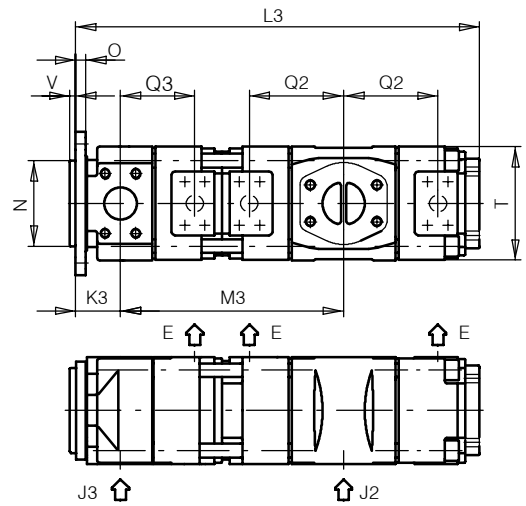
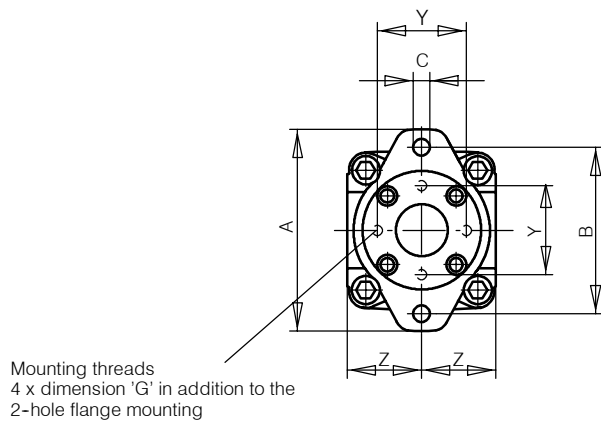
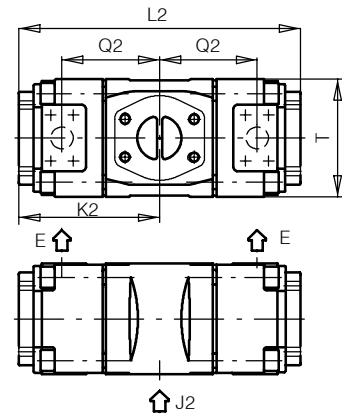
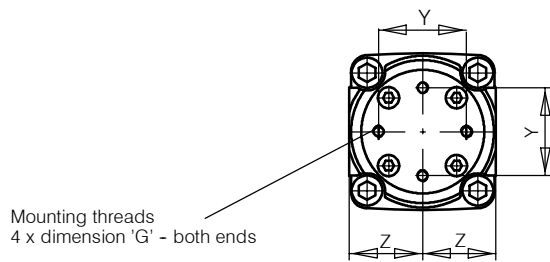

5 Ordering code

		<div style="display: flex; justify-content: space-around; border: 1px solid black; padding: 2px;"> QXT32 </div>	-	<div style="display: flex; justify-content: space-around; border: 1px solid black; padding: 2px;"> 012 </div>	/	<div style="display: flex; justify-content: space-around; border: 1px solid black; padding: 2px;"> 32 </div>	-	<div style="display: flex; justify-content: space-around; border: 1px solid black; padding: 2px;"> 012 </div>	/	<div style="display: flex; justify-content: space-around; border: 1px solid black; padding: 2px;"> </div>
Series	QXT									
Frame size	2 / 3 / 4 / 5 / 6 / 8									
Pressure range 2	2									
Outlet displacement	005 - 250									
Frame size	2 / 3 / 4 / 5 / 6 / 8									
Pressure range 2	2									
Outlet displacement	005 - 250									
Special features	(to be inserted by the plant)									

5.1 Ordering example

For dividers with 3 outlet flows:
QXT22-005 / 22-005 / 22-005

For dividers with 4 outlet flows:
QXT62-100 / 62-100 / 62-100 / 62-100

Flow divider combinations must contain the same frame sizes, pressure ranges and outlet flows.

If unequal flows are required, please contact BUCHER HYDRAULICS

BUCHER HYDRAULICS

Germany

Phone +49 7742 85 20
Fax +49 7742 71 16
info.de@bucherhydraulics.com

France

Phone +33 389 64 22 44
Fax +33 389 65 28 78
info.fr@bucherhydraulics.com

Netherlands

Phone +31 79 34 26 24 4
Fax +31 79 34 26 28 8
info.nl@bucherhydraulics.com

UK

Phone +44 24 76 35 35 61
Fax +44 24 76 35 35 72
info.uk@bucherhydraulics.com

USA

Phone +1 262 605 82 80
Fax +1 262 605 82 78
info.wi@bucherhydraulics.com

Switzerland

Phone +41 33 67 26 11 1
Fax +41 33 67 26 10 3
info.ch@bucherhydraulics.com

Italy

Phone +39 0522 92 84 11
Fax +39 0522 51 32 11
info.ch@bucherhydraulics.com

Austria

Phone +43 6216 44 97
Fax +43 6216 44 97 4
info.at@bucherhydraulics.com

China

Phone +86 10 64 44 32 38
Fax +86 10 684 44 32 35
info.bj@bucherhydraulics.com

Product Centre Elevator

Phone +41 41 757 03 33
Fax +41 41 755 16 49
info.nh@bucherhydraulics.com

We reserve the right to introduce technical modifications

www.bucherhydraulics.com